



Model FT05 Metallic

AIR OPERATED DOUBLE DIAPHRAGM PUMPS

Specifications

Suction & Discharge Size:	1/2" x 1/2"
Standard Porting Location*:	End
Connection Types:	NPT, BSP
Air Inlet & Air Exhaust Size:	1/4" FNPT x 1/2" FNPT

*Optional NPT or BSP threaded center port location in either horizontal or vertical position

Capabilities

Maximum Flow Rate:	20 gpm (77 lpm)
Maximum Air Supply Pressure:	120 psi (8.3 bar)
Displacement Per Stroke:	0.02 gal (0.08 lit)
Minimum Air Inlet Pressure:	10 psig (0.7 bar)
Maximum Particle Size :	0.19 in (4.7 mm)
Sound Pressure:	72.1 dB(A)
Operating Temperature:	Determined by elastomers

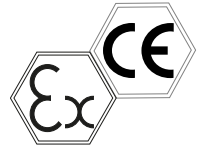

FT05 Performance

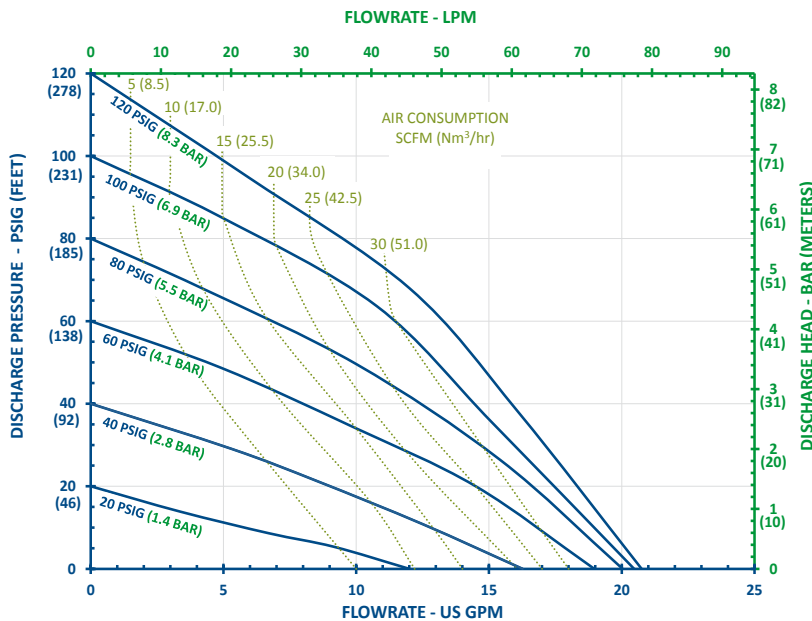

Note: Full stroke diaphragm allows performance to be equal for all elastomers.

Typical Applications

- Acids & Bases
- Plating Solutions
- Wastewater
- Paints, Inks, Solvents
- Ceramic Slip and Glaze
- Lubricants and Oils

Typical Industries

- Mining
- Paints and Coatings
- Ceramics
- Pulp and Paper
- Electroplating & Anodizing
- Wastewater
- Marine
- Chemical Manufacturing & Distribution
- OEM's

Pat. <http://ftiair.com/resources/ip/>

CHANGE IS IN THE AIR

Construction

Wetted Materials:	Aluminum, 316SS
Diaphragm Materials:	Neoprene, Santoprene™, FKM, EPDM, PTFE, Buna, Hytrel®, Polyurethane
Air Valve:	GFRPP, Aluminum
Ball Materials:	Neoprene, Buna, EPDM, FKM, Santoprene™, PTFE
Seat Materials:	Aluminum, 316SS, PTFE
O-ring Materials:	Neoprene, Buna, EPDM, FKM, PTFE, FEP/FKM

Santoprene™ is a registered trademark of Exxon Mobil Corp.
Hytrel® is a registered trademark of Dupont™

Pat. <http://ftiair.com/resources/ip/>

Dimensions

Maximum Height:	9-27/32 in (250 mm)
Maximum Width:	9-5/8 in (246 mm)
Maximum Depth:	8-1/16 in (204 mm)

Weight

Aluminum:	11.7 lb (5.3 kg)
Stainless Steel:	15.5 lb (7.0 kg)

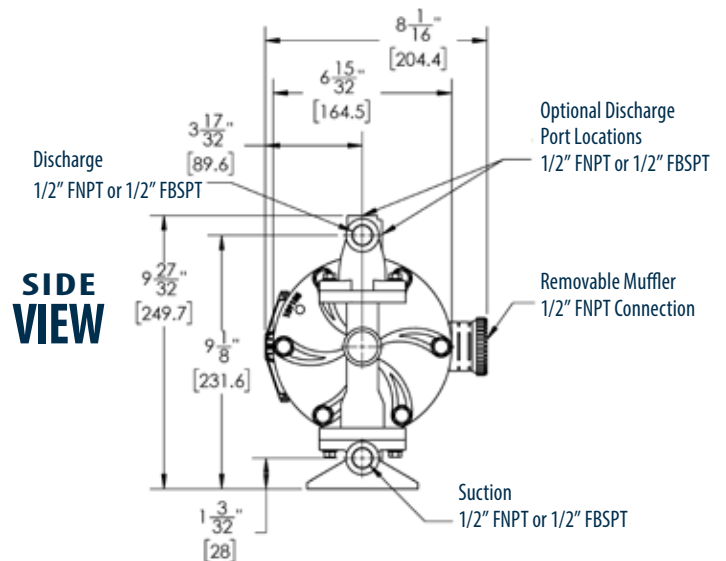
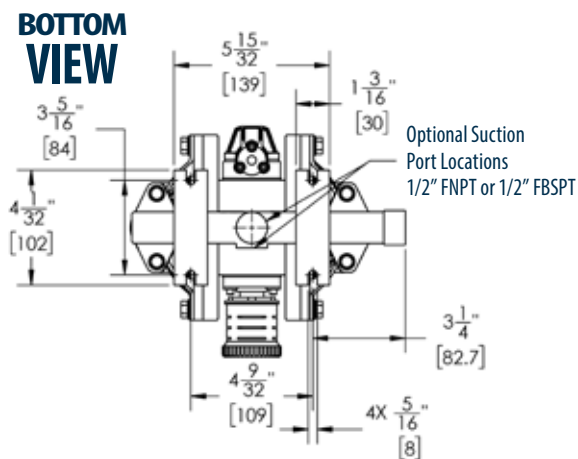
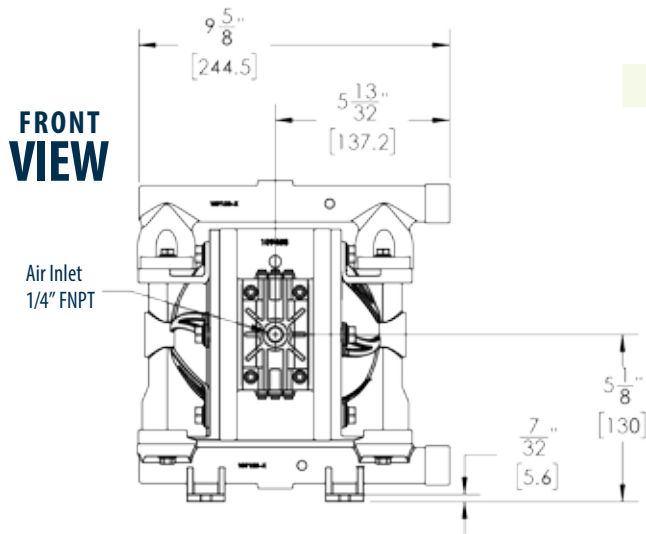

FTI AIR

921 GREENGARDEN ROAD ERIE, PA 16501
Tel: (800) 934-9384 • Fax: (814) 459-3460
www.FTIAIR.com

